

Name



WINCHESTER
COLLEGE

ELECTION

Mathematics 2

Wednesday 25 April 2018

Time allowed: 1 hour 30 minutes

Total marks: 100

Calculators are not allowed.

Write your answers in this booklet. If you need additional space, please write on sheets of A4 paper and attach them to this booklet. You may use a pencil for diagrams.

Work carefully, and *do not be discouraged if you do not finish.*

You should show your working so that credit may be given for partly correct answers.

1.	Evaluate: a) $2 \times 3^2 \times 5$	b) $\sqrt[3]{10^6}$	[1] [1]
	c) $\sqrt{3\frac{1}{16}}$	d) $\frac{27}{125} \div \frac{9}{25}$	[2] [2]
	e) $\frac{120000 + 3100 + 23}{1001}$	f) $\sqrt{2^6 \times 5^2}$	[2] [2]

2.	<p>Solve:</p> <p>a) $\sqrt{\sqrt{a} + 116} = 11$</p>	<p>b) $\frac{1009 + b + 3027 + 4036}{1009} = 10$</p>	<p>[2] [2]</p>
	<p>c) $\frac{\frac{888}{77} - 3}{\frac{50}{6+c} + 1} = 222$</p>	<p>d) $1155 = \frac{d}{\frac{5}{21} - \frac{8}{35}}$</p>	<p>[3] [4]</p>

3. The total surface area of a cylinder of radius r and height h is $2\pi r(r+h)$.
The surface area of a sphere of radius R is $4\pi R^2$.

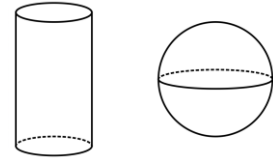

- a) A cylinder of radius 2 and height 7 has the same total surface area as a sphere of radius R . Find R .

[3]

The volume of a cone of radius r and height h is $\frac{1}{3}\pi r^2 h$; and the total surface area of a cone of radius r is $\pi r(r+l)$, where l is the slant height of the cone.

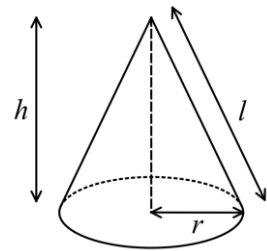

- b) The total surface area of a cone of radius 8 is 200π . Find the volume of the cone.
(*Hint*: you will need to use Pythagoras.)

[5]

4. a) The diagram below shows a rectangle. Find the shaded area.

[4]

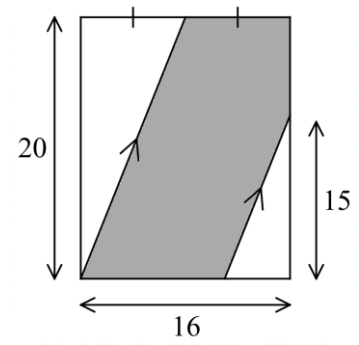

b) In the diagram below, lines that look straight are straight. Find the shaded area.

[4]

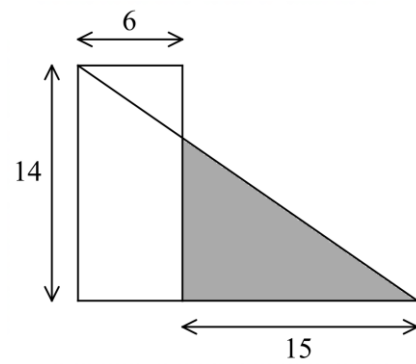

5. If x and y are non-negative whole numbers (including zero), the equation $3x + 4y = 48$ has five solutions. One of these solutions is $x = 12$, $y = 3$. This solution is shown by a cross on the graph below.

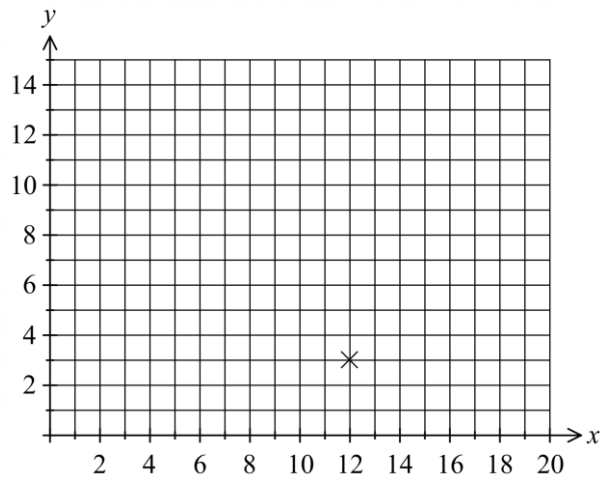

- a) Show the other solutions of the equation $3x + 4y = 48$ by drawing four more crosses on the graph.

[3]

- b) Find the number of solutions of the equation $3x + 4y = 480$, where x and y are non-negative whole numbers.

[3]

c) Use the diagram on the right to evaluate the sum below.

$$1+3+5+7+9+11+13= \dots\dots\dots$$

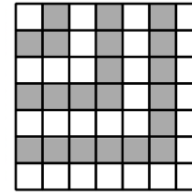

[1]

d) Find the number of solutions of the equation $x + y + 2z = 98$, where x , y and z are non-negative whole numbers.

[6]

6. The Shakespeare Company is performing *Measure for Measure* at the Cork Opera House. The diagram below shows the stage, which is a rectangle measuring eighty feet by sixty feet, and four lights, each thirty feet above a corner of the stage. So an actor standing on the stage casts four shadows.

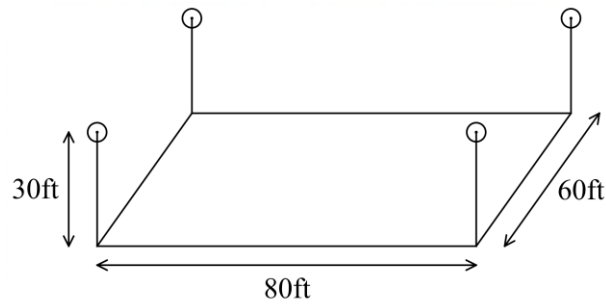

(Front of Stage)

- a) Vincentio is five feet tall, and on the stage. His shadows are all the same length. How long are they? (*Hint: the answer is a whole number of feet.*)

[4]

- b) Later on, Abhorson and Barnardine are standing at the back of the stage (see below). Abhorson is six feet tall and Barnardine is five feet tall. One of Abhorson's shadows just touches Barnardine's feet, and one of Barnardine's shadows just touches Abhorson's feet.

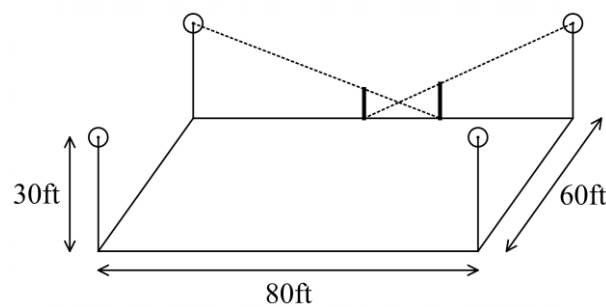

How far apart are they standing?

[5]

c) Later still, there is a carpet on the stage and Lucio is standing on it. The carpet is made out of squares sewn together. The edge of the carpet which is at the bottom in the diagram is parallel to the front of the stage.

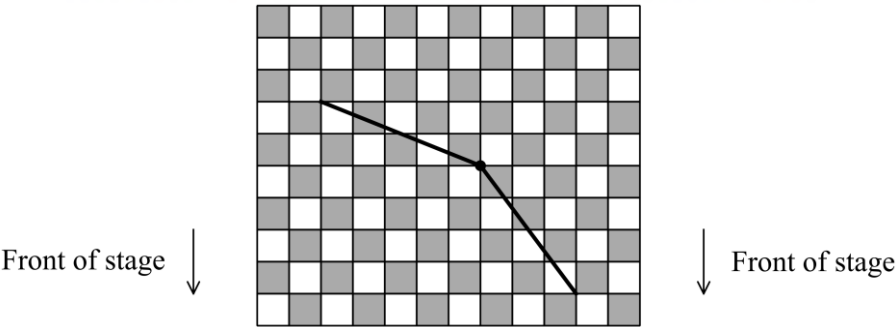

Two of Lucio's four shadows are shown in the diagram. Draw the other two shadows on the diagram.

How far is Lucio from the front of the stage?

7. a) Along a straight canal with still water, Arthur rows at constant speed eastwards, Brian rows at constant speed westwards, and Arthur rows 50% faster than Brian. At 1.00pm they are 720 metres apart. They pass each other four minutes later. How fast is Arthur rowing?

[4]

b) Along a straight canal with still water, Xanthe rows at a constant speed eastwards, Yasmin rows at a constant speed eastwards, and Zara rows at a constant speed westwards. At 3.00pm Xanthe and Zara are 900 metres apart, and Yasmin is halfway between them. Yasmin and Zara pass each other five minutes later. Xanthe and Zara pass each other at 3.06pm. When does Xanthe overtake Yasmin?

[8]

8. Maria has four identical treats to give to her five dogs, whose names are Apollo, Bacchus, Cronos, Diana and Eros. One way she could do this would be to give all four treats to Apollo. Another way would be to give one treat to Apollo, none to Bacchus, two to Cronos, one to Diana and none to Eros. Yet another way would be to give no treats to Apollo, none to Bacchus, three to Cronos, none to Diana and one to Eros.

How many different ways of handing out the treats are there? (There are more than fifty.)

[12]

9. a) The diagram below shows a right-angled triangle with a line drawn inside it. Fill in the five marked angles on the diagram.

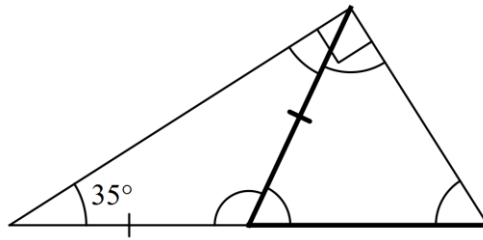

What can you say about the two bold lines?

[2]

- b) In the diagram below, the bold line is a straight line.

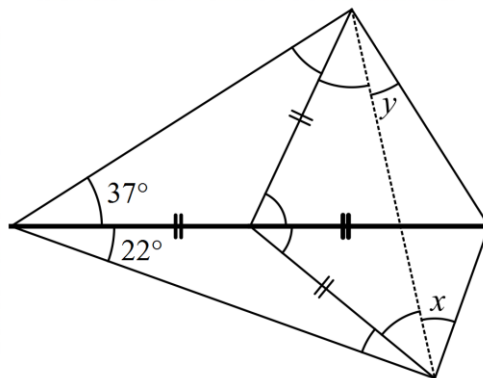

Find the values of x and y .

[3]

c)

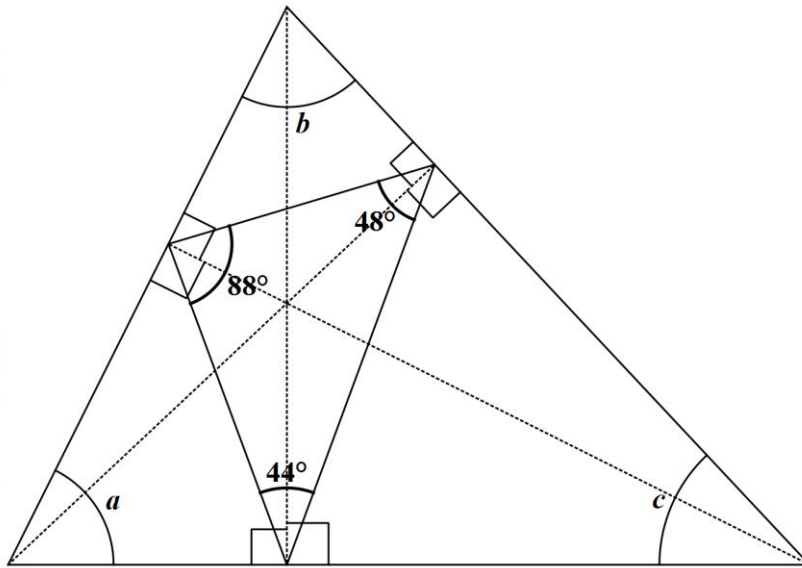

Find the values of a , b and c , the angles in the big triangle.

[7]

